

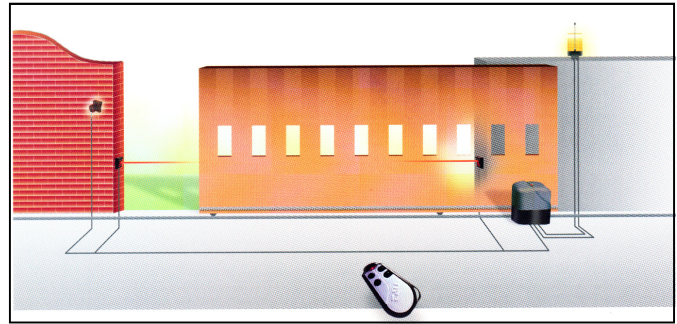

**350SPEED Series
Sliding Gate Openers
Maximum Gate Leaf Length
8 Metres**



Selecting the Right Automatic Gate Opener

We believe there are **three key decisions** to be made when selecting the right automatic gate system. Understand these and the type of TAU Gate Opening System you seek becomes a lot clearer, making the final decision one of which system provides the best fit for your application.

This data sheet is to assist you through this process, outlining how the Sliding Gate option with the TAU 350SPEED Series Automatic Gate Opener System will meet these three key decision areas.

Key Decision Area 1

Motives for automating your gates

Security

Your property's security is enhanced by the self-locking design of the TAU 350SPEED Series Gate Openers, minimising the possibility of an intruder opening the gates manually, even in the event of a power failure. An additional locking device is not required.

Protection

The TAU Built-in Sliding Gate Controllers have the ability to partially open the gate leaf for pedestrian access. This feature maximises the security of the premises by restricting full access.

Manual Operation

There is a manual release feature, protected by a Personal Key, for opening the gates in the event of a power failure.

The 12Vdc TAU 350SPEED2Q Series Motors' Controller has a built-in battery charger and provision for a back-up battery, for operation during a power failure.

Aesthetic Appeal

The compactness of the TAU 350SPEED Series Motors means they are unobtrusive, enabling the gate to be a feature without operational parts being highly visible.

Key Decision Area 2

Performance requirements for your gates.

This is where the expectations for performance are matched against the capabilities of the TAU 350SPEED Series Sliding Gate Openers.

There are two versions available:

230 Volts ac version for normal residential and light industrial use.

12 Volts dc version for more intensive residential and light industrial use. In the event of a power failure, it is able to powered by an optional 12Vdc Rechargeable Back-up Battery, which enables the gates to continue working up to 10 operations in a 24 hour period.

Performance Required	350SPEED8QR	350SPEED2Q
Gate Length	Up to 8 metres per leaf open style gate design	
Gate Opening Time (approx)	180 mm per second	233 mm per second
Usage per hour	Up to 8 times	Up to 30 times
System Power Requirement	Mains power only	Mains Power and Battery Back-up Operation
Weight of Gate	Up to 800 kgs	Up to 400 kgs

Dimensions

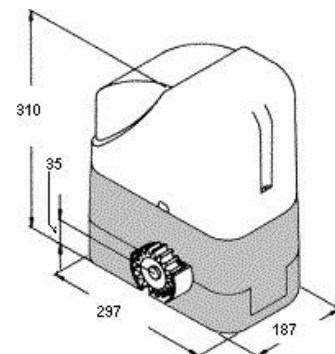

GATE AUTOMATION CONTROL EQUIPMENT

Key Decision Area 3

Operational Requirements for your gates

How you want to be able to use your gates is an important aspect of the decision of which Automatic Sliding Gate Opening System will suit you best. Key components of control for effective operation includes:-

- **Remote Control**

Each TAU 350SPEED Series Automatic Gate Opening System is supplied with 2 TAU Remote Controls which can be programmed into the main system. Additional units can be ordered and programmed as required.

- **Keypad entry**

For those who require visitor entry, an optional weather durable TAU Radio Keypad, located outside of the gate is available and can be positioned at a suitable height at the entrance way. The TAU Radio Keypad has a range of 10-20 metres and offers up to 10 individual user codes.

- **Photocells**

It is recommended that each TAU 350SPEED Series Automatic Gate Opening System is installed with a set of safety Photocells that recognise an obstacle is across the gateway, preventing the gates closing until the obstacle is removed.

- **Safety features**

The TAU 350K550 Controller used with the TAU 350SPEED8QR 230Vac Motors has an electrical anti-crush safety clutch.

The TAU 350K122M Controller used with the TAU 350SPEED2Q 12Vdc Motors has an electronically controlled, anti-crush safety clutch.

- **Automatic realignment**

The TAU 350K550 and TAU 350K122M Series Controllers include an Automatic Realignment feature, that ensures the first operation (Radio Remote or other opening/closing signal device) upon the power being restored, will realign the gates to the last state before the power was disconnected.

- **Minimal noise production**

The TAU 350SPEED2Q Series 12Vdc motors are fitted with an Encoder — a special detection system which moves the gate rapidly, then slows it down towards the end of its travel, in order to prevent noisy impacts and rebounds.

Accessories

Remotes
SLIM & BUG4
2 & 4 channel Remotes



SLIM

BUG4

Keypads
300TSP-ET
Radio Keypad
10 User Code



Photocells
900FOTE
Range 15 metres

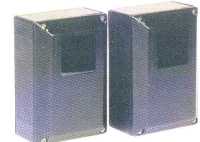

Control Devices

Controllers
350K550
For 230Vac Sliding
Gate Openers

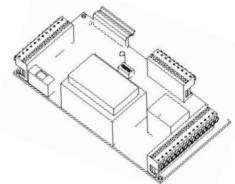

350K122M
For 12Vdc Sliding
Gate Openers

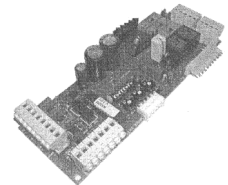

Radio Receivers
Plug-in Radio Receivers
1 & 2 channel

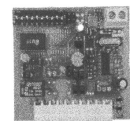

Universal Radio Receivers
Single channel options
interface to existing
Garage Door Openers

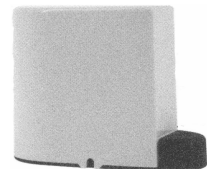

Your Local Installer